

This Page Is Inserted by IFW Operations  
and is not a part of the Official Record

## **BEST AVAILABLE IMAGES**

Defective images within this document are accurate representations of the original documents submitted by the applicant.

Defects in the images may include (but are not limited to):

- BLACK BORDERS
- TEXT CUT OFF AT TOP, BOTTOM OR SIDES
- FADED TEXT
- ILLEGIBLE TEXT
- SKEWED/SLANTED IMAGES
- COLORED PHOTOS
- BLACK OR VERY BLACK AND WHITE DARK PHOTOS
- GRAY SCALE DOCUMENTS

**IMAGES ARE BEST AVAILABLE COPY.**

**As rescanning documents *will not* correct images,  
please do not report the images to the  
Image Problem Mailbox.**



## INTERNATIONAL APPLICATION PUBLISHED UNDER THE PATENT COOPERATION TREATY (PCT)

(51) International Patent Classification <sup>6</sup> : B29B 17/02, C10C 3/00 // B29K 95:00	A1	(11) International Publication Number: <b>WO 98/31519</b> (43) International Publication Date: 23 July 1998 (23.07.98)
<p>(21) International Application Number: PCT/NL98/00028</p> <p>(22) International Filing Date: 16 January 1998 (16.01.98)</p> <p>(30) Priority Data: 1005029 17 January 1997 (17.01.97) NL</p> <p>(71) Applicant (for all designated States except US): MODIGLASS MODIFIED ASPHALT- AND GLASSMATMACHINES LTD. [CH/CH]; Bahnhofstrasse 27, CH-6304 Zug (CH).</p> <p>(72) Inventor; and (75) Inventor/Applicant (for US only): MUELBECK, Martin [AT/AT]; A-5222 Pfaffstaedt 10 (AT).</p> <p>(74) Agent: KOOMEN, M., J., I.; Kennemerstraatweg 35-37, NL-1814 GB Alkmaar (NL).</p>	<p>(81) Designated States: AL, AM, AT, AT (Utility model), AU, AZ, BA, BB, BG, BR, BY, CA, CH, CN, CU, CZ, CZ (Utility model), DE, DE (Utility model), DK, DK (Utility model), EE, EE (Utility model), ES, FI, FI (Utility model), GB, GE, GH, GM, GW, HU, ID, IL, IS, JP, KE, KG, KP, KR, KZ, LC, LK, LR, LS, LT, LU, LV, MD, MG, MK, MN, MW, MX, NO, NZ, PL, PT, RO, RU, SD, SE, SG, SI, SK, SK (Utility model), SL, TJ, TM, TR, TT, UA, UG, US, UZ, VN, YU, ZW, ARIPO patent (GH, GM, KE, LS, MW, SD, SZ, UG, ZW), Eurasian patent (AM, AZ, BY, KG, KZ, MD, RU, TJ, TM), European patent (AT, BE, CH, DE, DK, ES, FI, FR, GB, GR, IE, IT, LU, MC, NL, PT, SE), OAPI patent (BF, BJ, CF, CG, CI, CM, GA, GN, ML, MR, NE, SN, TD, TG).</p> <p>Published With international search report. In English translation (filed in Dutch).</p>	

(54) Title: METHOD AND APPARATUS FOR RECYCLING OF BITUMINOUS MATERIALS, MORE IN PARTICULAR BITUMINOUS ROOFING MATERIALS

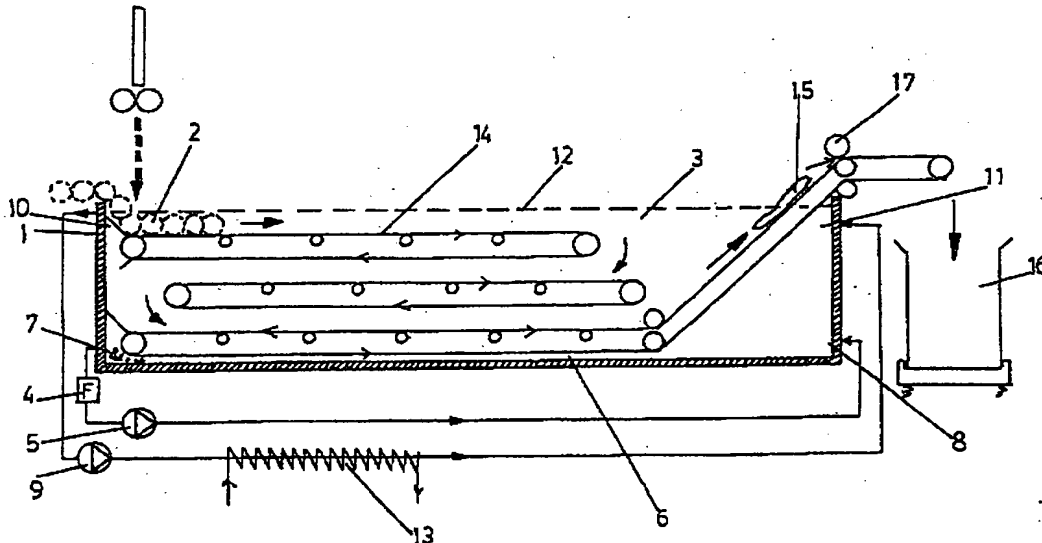

## (57) Abstract

Method for recycling bituminous materials, more in particular for recycling bituminous roofing materials, made up of bitumen and other components from roofing material, such as insulation materials made up of polystyrene, polyurethane, mineral wool and such like and components such as slate chippings, polyester fleece and glass fleece or -fabric, while the bituminous materials are heated, in such a way that the bitumen component in the bituminous materials melts, while the bitumen and the other components from the roofing material are separated.

**FOR THE PURPOSES OF INFORMATION ONLY**

Codes used to identify States party to the PCT on the front pages of pamphlets publishing international applications under the PCT.

AL	Albania	ES	Spain	LS	Lesotho	SI	Slovenia
AM	Armenia	FI	Finland	LT	Lithuania	SK	Slovakia
AT	Austria	FR	France	LU	Luxembourg	SN	Senegal
AU	Australia	GA	Gabon	LV	Larvia	SZ	Swaziland
AZ	Azerbaijan	GB	United Kingdom	MC	Monaco	TD	Chad
BA	Bosnia and Herzegovina	GE	Georgia	MD	Republic of Moldova	TG	Togo
BB	Barbados	GH	Ghana	MG	Madagascar	TJ	Tajikistan
BE	Belgium	GN	Guinea	MK	The former Yugoslav Republic of Macedonia	TM	Turkmenistan
BF	Burkina Faso	GR	Greece	ML	Mali	TR	Turkey
BG	Bulgaria	HU	Hungary	MN	Mongolia	TT	Trinidad and Tobago
BJ	Benin	IE	Ireland	MR	Mauritania	UA	Ukraine
BR	Brazil	IL	Israel	MW	Malawi	UG	Uganda
BY	Belarus	IS	Iceland	MX	Mexico	US	United States of America
CA	Canada	IT	Italy	NE	Niger	UZ	Uzbekistan
CF	Central African Republic	JP	Japan	NL	Netherlands	VN	Viet Nam
CG	Congo	KE	Kenya	NO	Norway	YU	Yugoslavia
CH	Switzerland	KG	Kyrgyzstan	NZ	New Zealand	ZW	Zimbabwe
CI	Côte d'Ivoire	KP	Democratic People's Republic of Korea	PL	Poland		
CM	Cameroon	KR	Republic of Korea	PT	Portugal		
CN	China	KZ	Kazakistan	RO	Romania		
CU	Cuba	LC	Saint Lucia	RU	Russian Federation		
CZ	Czech Republic	LI	Liechtenstein	SD	Sudan		
DE	Germany	LK	Sri Lanka	SE	Sweden		
DK	Denmark	LR	Liberia	SG	Singapore		
EE	Estonia						

Method and apparatus for recycling bituminous materials, more in particular bituminous roofing materials.

5 The invention relates to a method and apparatus for recycling bituminous materials, more in particular bituminous roofing materials.

10 During the production of bituminous roofing rolls a waste percentage arises between 1% and 2%. A part of these waste rolls is sold as second or B choice, while the remainder will go to a waste treatment and eventually will be burned. Dumping of the waste is costly.

15 When roofs are pulled down bituminous roofing material is obtained to which often insulation material is still attached. This material also goes to a waste treatment. This material, which is not separated, that is to say, in which the insulation and the roofing form one whole, provides a large problem because the combination may be made up of bituminous rolls with a polystyrene insulation, a polyurethane insulation or a mineral wool insulation and such like. It is clear that this poses a big environmental problem.

25 The present invention aims to provide a method for recycling bituminous materials, more in particular for recycling bituminous roofing materials, which are made up of bitumen and other components from roofing material such as inlaids or insulation materials made of polyurethane, mineral wool and such like and components such as slate chippings, polyester fleece or glass fleece or -fabric and such like.

30 The method according to the invention to that end is characterized in that the bituminous materials are heated, in such a way that the bitumen component in the bituminous materials melts, while the bitumen and the other components from the roofing material are separated.

35

According to a characteristic of the method according to the invention the bituminous material is heated by leading high temperature bitumen at great speed along the bituminous material that is to be melted.

5 According to another characteristic of the method according to the invention the bitumen by means of which the bituminous material is melted consists of oxidized or non-oxidized bitumen of ca 200 °C.

10 According to a further characteristic the bitumen is separated from the remainder of the components of the bituminous material by means of baskets or strainers.

The invention further relates to an apparatus for applying a method for recycling bituminous materials, more in particular for recycling bituminous roofing materials, formed by bitumen and other components from roofing material, such as insulation materials made up of polystyrene, polyurethane, mineral wool and such like and components such as slate chippings, polyester fleece and glass fleece or -fabric, formed by a vessel for receiving the bituminous materials, with means for the feeding into the vessel of bitumen, with means for containing the bituminous materials, with means for bringing the content into a flow, with means for heating the content, and with means for filtering or sieving the content, and with means for discharging the sieved or filtered non-bituminous components.

According to a further characteristic of the invention means are present for conveying the bituminous materials within the vessel.

30 There are several ways in which the rolls can be melted.

Within the vessel according to a characteristic of the invention baskets are present in which one or two rolls can be put. After this the vessel is filled up with bitumen up to a level above the rolls and the pumps are operated. After a while the rolls will be melted and the slate chippings, if present, remain in the filter and the inlaid of the polyester fleece or glass fleece will remain behind in the baskets or strainers. The recovered bitumen and any polymers are pumped back into the system via the filter for the production of for instance bituminous roofing rolls.

Further characteristics and particulars are given in the description following hereafter with reference to a drawing of an example of an embodiment.

The drawing shows a vessel according to the invention for recycling bituminous roofing, whereby use is made of a conveyor belt mounted within the vessel for receiving the bituminous materials.

As can be seen in the drawing, bituminous bands 2 including the slate chippings, the inlaid and any insulation material attached thereto are put into a vessel 1. The vessel is filled up to a level above the material with non-blown bitumen 3 of ca 200 °C. The vessel is provided with one or more filters 4 with openings having a size of 1 to 10 mm.

Further a pump 5 is provided which is connected to the bottom 6 and which carries all impurities such as slate chippings through the filter 4 and whereby purified bitumen 8 is carried back. A second pump device 9 is provided which suctions the bitumen at the upper surface 10 out of the vessel 1 and carries this back to the other side 11 of the vessel, also at the upper surface. The polymers which come to float at the upper surface during the melting of the rolls are suctioned

out and mixed with bitumen.

The system that develops in this manner has a strong horizontal flow at the bottom 6, which takes care of the discharge of impurities 7, as well as at the  
5 surface 12 which takes care of the molten and floating polymers being carried out of the vessel and being again mixed via the pump and the return system.

A difference can be made between rolls without insulation being attached thereto and rolls to which  
10 insulation is attached. For both systems a high velocity of liquid flow of the bitumen is important because the heat transfer for the melting process is dependant on the square of the velocity of the flow. By means of a double walled construction of the vessel or  
15 the piping system extra energy can and/or must be supplied by means of a hot oil circulation system 13.

In the vessel a steel conveyor belt 14 is further provided onto which the melting rolls 2 are being moved slowly and are conveyed to the back side of the vessel  
20 and where this belt under an angle of ca 30 ° runs sloping upward out of the vessel and onto which the rest 15 of the inlaid and further waste materials can be dumped into a waste container 16. The apparatus can further be provided with a press device 17 by means of  
25 which the rest 15 of the inlaid and other materials can be removed from the bitumen being attached thereto as much as possible before it is dumped into the waste container.

The proportions of the vessel can be a width of 2 meter and a length of 10 meter. Such a system is suitable for  
30 processing ca 2000 m<sup>2</sup> per 24 hours. In another embodiment whereby the material that is to be recycled is formed by roofcovering materials which have come up

from a demolition and whereby the insulation is attached to the bituminous roofing the vessel will have much larger proportions, having a width of ca 4 meter to a length of ca 40 meter. In that case use will be made of a metal belt moving slowly forward through the vessel. The bitumen will be melted by the high temperature and high velocity circulating bitumen flows. The impurities such as inlaid, slate chippings, parts of insulation plates and such like will be slowly discharged from out of the melting vessel by the conveyor belt and discharged into the container.

The invented recycling system unburdens the environment in the sense that the recovered bitumen can be used again and again. The bitumen which is pulled down from the roof has only slightly aged and can easily be brought into to an excellent quality again by the adding and mixing of polymers.



## C l a i m s

1. Method for recycling bituminous materials, more in particular for recycling bituminous roofing materials, made up of bitumen and other components from roofing material, such as insulation materials made up of polystyrene, polyurethane, mineral wool and such like and components such as slate chippings, polyester fleece and glass fleece or -fabric, characterized in that the bituminous materials are heated, in such a way that the bitumen component in the bituminous materials melts, while the bitumen and the other components from the roofing material are separated.
2. Method according to claim 1, characterized in that the bituminous material is heated by leading high temperature bitumen at great speed along the bituminous material that is to be melted.
3. Method according to claim 2, characterized in that the bitumen by means of which the bituminous material is melted consists of oxidized or non-oxidized bitumen of ca 200 °C.
4. Method according to one of the preceding claims, characterized in that the bitumen is separated from the remainder of the components of the bituminous material by means of filters.
5. Method according to one of the preceding claims, characterized in that the bitumen is separated from the remainder of the components of the bituminous material by means of baskets or strainers.
6. Method according to one of the preceding claims, characterized in that the bitumen is separated from the remainder of the components of the bituminous material

by means of a perforated or non-perforated conveyor belt.

5 7. Apparatus for applying a method for recycling bituminous materials, more in particular for recycling bituminous roofing materials, formed by bitumen and other components from roofing material, such as insulation materials made up of polystyrene, polyurethane, mineral wool and such like and components such as slate chippings, polyester fleece and glass fleece or  
10 -fabric, formed by a vessel for receiving the bituminous materials, with means for the feeding into the vessel of bitumen, with means for containing the bituminous materials, with means for bringing the content into a flow, with means for heating the content,  
15 and with means for filtering or sieving the content, and with means for discharging the sieved or filtered non-bituminous components.

20 8. Apparatus according to claim 7, characterized in that means are present for conveying the bituminous materials within the vessel.

9. Apparatus according to claim 7, characterized in that the means for filtering the content are formed by one or more filters.

25 10. Apparatus according to claim 9, characterized in that the filters are provided with openings having a size of between 0,5 mm up to 10 mm.

30 11. Apparatus according to one of the preceding claims, characterized in that the apparatus is provided with a perforated or non-perforated conveyor belt for conveying the bituminous material forward within the vessel and for discharging it from out of the vessel.

12. Apparatus according to one of the preceding claims, characterized in that the apparatus is provided with strainers or baskets for containing the bituminous material.
- 5 13. Apparatus according to one of the preceding claims, characterized in that the means for circulating the content are formed by one or more pumps.
14. Apparatus according to one of the preceding claims, characterized in that the means for heating the content  
10 are formed by a heat exchanger.
15. Apparatus according to one of the preceding claims, characterized in that the apparatus is provided with means by means of which the rest of of the non-bituminous waste materials after the melting process may  
15 stripped of bitumen which is attached to it.
16. Apparatus according to claims 15, characterized in that the means are formed by a press device.

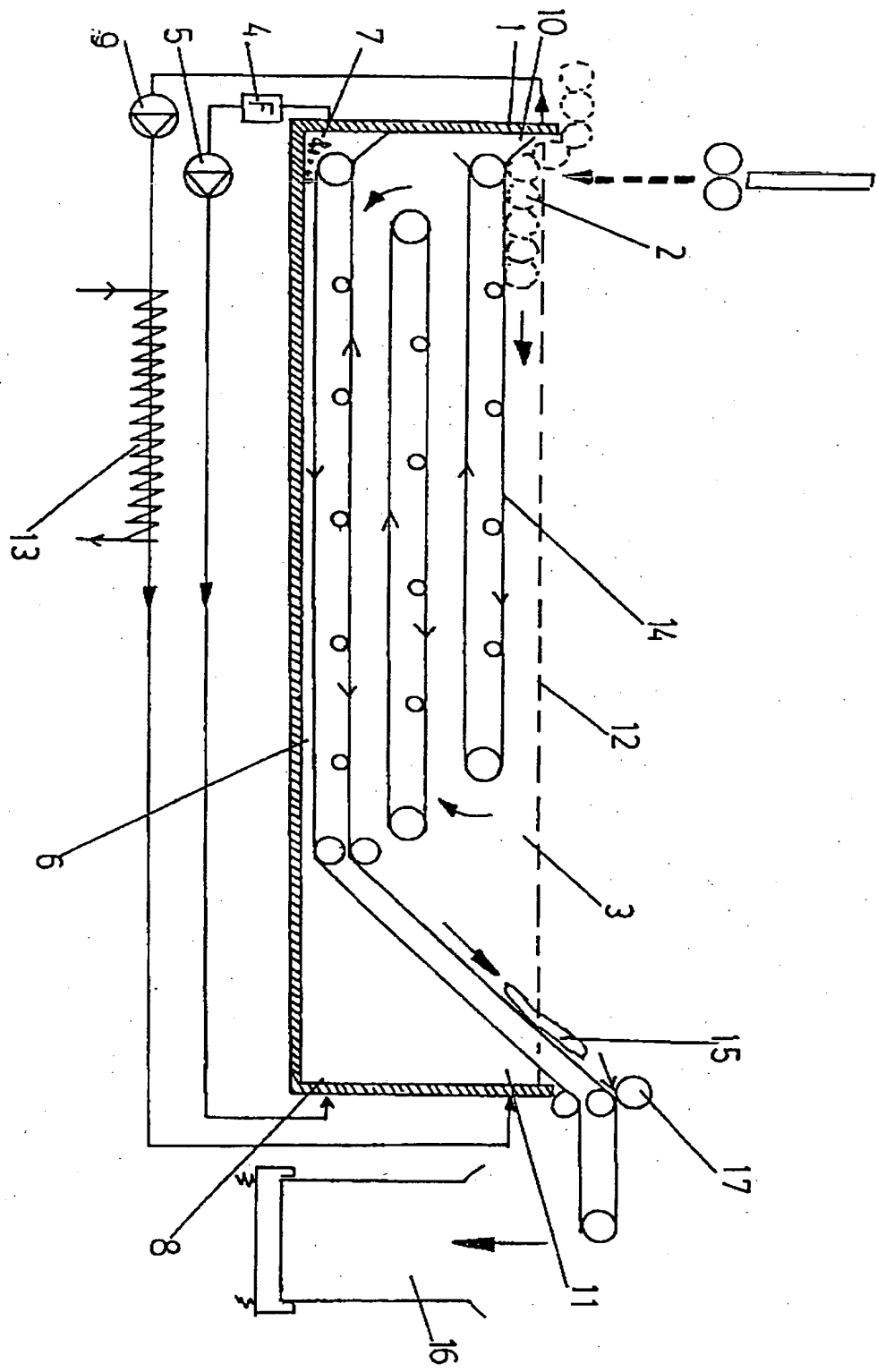

# INTERNATIONAL SEARCH REPORT

Inte:      mal Application No  
PCT/NL 98/00028

**A. CLASSIFICATION OF SUBJECT MATTER**  
IPC 6   B29B17/02   C10C3/00   //B29K95:00

According to International Patent Classification (IPC) or to both national classification and IPC

**B. FIELDS SEARCHED**

Minimum documentation searched (classification system followed by classification symbols)  
IPC 6   B29B   C10C   C08L   B03B   B09B

Documentation searched other than minimum documentation to the extent that such documents are included in the fields searched

Electronic data base consulted during the international search (name of data base and, where practical, search terms used)

**C. DOCUMENTS CONSIDERED TO BE RELEVANT**

Category *	Citation of document, with indication, where appropriate, of the relevant passages	Relevant to claim No.
X A	US 4 330 340 A (WAYNE H. CARLTON) 18 May 1982 see the whole document	1-3,6, 11,13,15 8
X	PATENT ABSTRACTS OF JAPAN vol. 14, no. 386 (C-0750), 21 August 1990 & JP 02 144187 A (KYUSHU NOZAWA K.K.), 1 June 1990, see abstract	1,2,4,7, 9,10,14
X	DE 41 28 014 A (RÜTGERSWERKE AG) 25 February 1993 see the whole document see example 1	1-4,7,9, 10
P,X	DE 196 12 971 C (BETTINA LINDNER) 26 June 1997 see the whole document	1,4
-/--		

Further documents are listed in the continuation of box C.

Patent family members are listed in annex.

\* Special categories of cited documents :

- "A" document defining the general state of the art which is not considered to be of particular relevance
- "E" earlier document but published on or after the international filing date
- "L" document which may throw doubts on priority claim(s) or which is cited to establish the publication date of another citation or other special reason (as specified)
- "O" document referring to an oral disclosure, use, exhibition or other means
- "P" document published prior to the international filing date but later than the priority date claimed

- "T" later document published after the international filing date or priority date and not in conflict with the application but cited to understand the principle or theory underlying the invention
- "X" document of particular relevance; the claimed invention cannot be considered novel or cannot be considered to involve an inventive step when the document is taken alone
- "Y" document of particular relevance; the claimed invention cannot be considered to involve an inventive step when the document is combined with one or more other such documents, such combination being obvious to a person skilled in the art.
- "&" document member of the same patent family

Date of the actual completion of the international search

26 March 1998

Date of making of the international search report

02/04/1998

Name and mailing address of the ISA  
European Patent Office, P.B. 5818 Patentlaan 2  
NL - 2280 HV Rijswijk  
Tel. (+31-70) 340-2040, Tx. 31 651 epo nl,  
Fax: (+31-70) 340-3016

Authorized officer

Molto Pinol, F

## INTERNATIONAL SEARCH REPORT

International Application No  
PCT/NL 98/00028

C.(Continuation) DOCUMENTS CONSIDERED TO BE RELEVANT		
Category *	Citation of document, with indication, where appropriate, of the relevant passages	Relevant to claim No.
A	<p>DATABASE WPI Section Ch, Week 8412 Derwent Publications Ltd., London, GB; Class LQ, AN 84-072083 (12) XP002039397 &amp; JP 59 027 007 A (CHIYODA RES. &amp; DEV. K.K.), 13 February 1984 see abstract</p>	1,4, 7-10,14
A	<p>DATABASE WPI Section Ch, Week 8423 Derwent Publications Ltd., London, GB; Class HQ, AN 84-143804 (23) XP002039398 &amp; JP 59 076 302 A (WATANABE GUMI K.K.), 1 May 1984 see abstract</p>	1,4,7,9, 10,14
A	<p>US 5 518 606 A (DWIGHT R. MOHLE) 21 May 1996 see the whole document</p>	1,5,7,12
A	<p>US 4 269 693 A (ANTHONY M. B. HASTIE) 26 May 1981 see the whole document</p>	1,4,7,9, 15

# INTERNATIONAL SEARCH REPORT

Information on patent family members

International Application No

PCT/NL 98/00028

Patent document cited in search report	Publication date	Patent family member(s)	Publication date
US 4330340 A	18-05-82	NONE	
DE 4128014 A	25-02-93	AT 121444 T DE 59201965 D EP 0531622 A	15-05-95 24-05-95 17-03-93
DE 19612971 C	26-06-97	AU 2291197 A WO 9736725 A	22-10-97 09-10-97
US 5518606 A	21-05-96	NONE	
US 4269693 A	26-05-81	GB 1558320 A	19-12-79